



INSTRUCTION MANUAL

HF AUTOMATIC TUNING ANTENNA
AH-740

Icom Inc.



*The “stand” in the photo is not supplied with the tuning antenna.

Thank you for purchasing the AH-740 HF AUTOMATIC TUNING ANTENNA.

The AH-740 is designed, primarily for use with Icom HF transceivers.

Refer to your HF transceiver instruction manual for operation. If you have any questions, contact your dealer.

IMPORTANT

READ ALL INSTRUCTIONS carefully and completely before using the AH-740.

SAVE THIS INSTRUCTION MANUAL. This instruction manual contains important safety and installation instructions.

FEATURES

- Compact and light weight
- Fast tuning speed
- Covers 2.2 to 30 MHz range when using with the optional NVIS kit

ABOUT CE AND DOC



Hereby, Icom Inc. declares that the versions of AH-740 which have the “CE” symbol on the product, comply with the essential requirements of the Radio Equipment

Directive, 2014/53/EU, and the restriction of the use of certain hazardous substances in electrical and electronic equipment Directive, 2011/65/EU. The full text of the EU declaration of conformity is available at the following internet address: <https://www.icomjapan.com/support/>

DISPOSAL



The crossed-out wheeled-bin symbol on your product, literature, or packaging reminds you that in the European Union, all electrical and electronic products, batteries, and accumulators (rechargeable batteries) must be taken to designated collection locations at the end of their working life. Do not dispose of these products as unsorted municipal waste. Dispose of them according to the laws in your area.

Below statement is for UKCA purpose only

United Kingdom Authorised Importer: Icom (UK) Ltd.
Address: Blacksole House, Altira Park, Herne Bay, Kent, CT6 6GZ, U.K.

To obtain the UKCA Declaration of Conformity, please contact Icom UK Limited by email at info@icomuk.co.uk or alternatively call + 44(0) 1227 741741.

EXPLICIT DEFINITIONS

WORD	DEFINITION
⚠ DANGER!	Personal death, serious injury or an explosion may occur.
⚠ WARNING!	Personal injury, fire hazard or electric shock may occur.

PRECAUTIONS

⚠ **DANGER HIGH VOLTAGE! NEVER** touch the antenna terminal, ground terminal, antenna while transmitting.

⚠ **WARNING! NEVER** transmit while installing the antenna. This may cause an electric shock.

NEVER use without a ground connection.

USE the ground terminal for ground connection.

DO NOT operate your HF transceiver without running the vehicle's engine. When the transceiver's power is ON and the vehicle's engine is OFF, the vehicle's battery will soon become exhausted.

DO NOT use the AH-740 in areas where the temperature is below -40°C (-40°F) or above $+70^{\circ}\text{C}$ ($+158^{\circ}\text{F}$).

Icom and the Icom logo are registered trademarks of Icom Incorporated (Japan) in Japan, the United States, the United Kingdom, Germany, France, Spain, Russia, Australia, New Zealand, and/or other countries. All other products or brands are registered trademarks or trademarks of their respective holders.

TABLE OF CONTENTS

IMPORTANT.....	i
FEATURES.....	i
ABOUT CE AND DOC.....	i
DISPOSAL.....	i
EXPLICIT DEFINITIONS.....	ii
PRECAUTIONS.....	ii
SUPPLIED ACCESSORIES.....	iii
MISCELLANEOUS ITEMS.....	iii
1 SYSTEM INSTALLATION.....	1
■ Ground connection.....	1
■ Cabling.....	1
■ Coaxial cable.....	1
■ About mounting base.....	1
2 INSTALLATIONS.....	2
■ Typical installation scenarios.....	2
◇ Precautions when the optional AH-5NV is installed on a vehicle.....	3
■ Installation outline.....	4
■ Mounting.....	4
■ Cable connections.....	5
■ Optional AH-5NV.....	6
3 SPECIFICATIONS AND OPTIONS.....	7
■ Specifications.....	7
◇ Control connector information.....	7
■ Options.....	7

SUPPLIED ACCESSORIES

The following accessories are supplied with the antenna.

① Control cable (approximately 6 m, 19.7 ft)	1
② Coaxial cable (approximately 6 m, 19.7 ft)	1
③ Whip antenna	1
④ Antenna spring	1
⑤ Bolts (M8)	2
⑥ Nuts (M8)	2
⑦ Spring washers (M8)	2
⑧ Flat washers (M8)	4
⑨ Spring washer (M16)	1
⑩ Nut (M16)	1
⑪ Flat washer (M16)	1

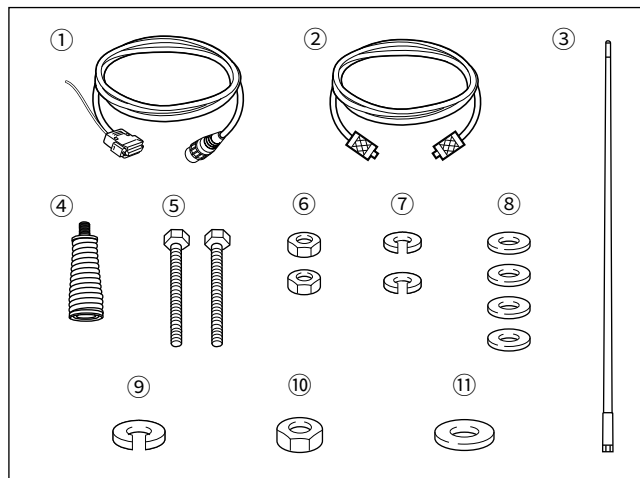

MISCELLANEOUS ITEMS

The following items are additionally required for installation, but is not supplied with the AH-740.

Purchase the item locally.

- Mounting base
- Rubber vulcanizing tape
- Electrical tape

Icom is not responsible for the destruction, damage to, or performance of any Icom or non-Icom equipment, if the malfunction is because of:

- Force majeure, including, but not limited to, fires, earthquakes, storms, floods, lightning, other natural disasters, disturbances, riots, war, or radioactive contamination.
- The use of Icom products with any equipment that is not manufactured or approved by Icom.

■ Ground connection

It is absolutely essential that the antenna is connected to an effective and stable RF GROUND POINT—the vehicle chassis. It is further recommended that body panels are also bonded to the vehicle chassis. Make sure all contact points are free of paint and ground to a shiny finish and protected from rusting with conductive grease, before bolting the mounting stud and ground strap terminals.

■ Cabling

A coaxial cable and a control cable are supplied with the tuning antenna. A ground strap is provided on the base of the tuning antenna to ensure a reliable connection with the vehicle's metalwork. Connect the ground strap to both the chassis frame or the body metalwork, whenever possible. Avoid feeding the antenna cables together with the engine ignition cabling routes. Use a One-Point (Star) Station Ground for the entire HF system where your transceiver is installed. Feed both (B+ and B-) thick wires from the vehicle battery to the transceiver location. Do not use the vehicle's metalwork as a replacement of the B- wire.

Use suitable noise filters for alternators. Ask your dealer for details.

■ Coaxial cable

Insulate the lead-in cable of the AH-740 antenna terminal and antenna element from other metal objects. To prevent interference, keep cables as far as possible from other antennas and electronic equipment.

■ About mounting base

A mounting base for the AH-740 installation must be locally prepared.

Select or fabricate a strong metal bracket for the antenna plate, about 8–10 mm (0.31–0.39 inches) thick, and weld or bolt it firmly to the vehicle chassis or other strong structure.

Ask your technical dealer or installer for suitable mounting base details.

■ Typical installation scenarios

Most recommended SUV installation scenarios use a Universal Gibbet Mounting System (front) or the Spare Wheel Antenna Bracket (rear). Note the tuning antenna unit is kept clear of the vehicle's hood and other metal panels. Best communications in all directions is ensured.

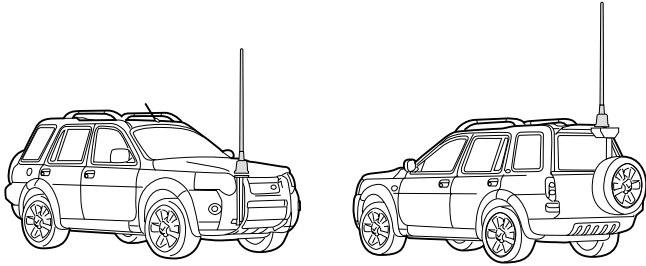

Recommended installation options on a typical pickup vehicle use a Universal Gibbet Mounting System (front) and a customer provided bracket (middle). Both methods provide effective communications in all directions.

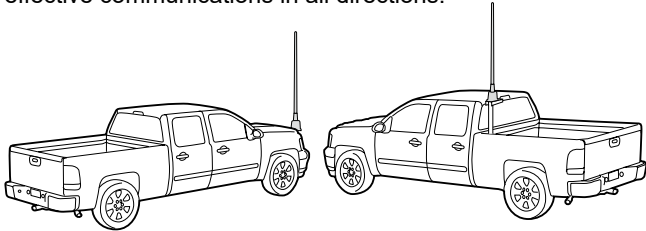

Recommended installation options on a typical sedan vehicle use a Universal Gibbet Mounting System for both front and rear antenna locations. Note the tuning antenna unit is optimally raised above the trunk and hood of the vehicle.

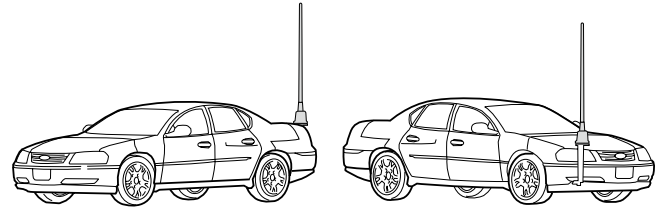

NON-RECOMMENDED installation methods use a Universal Gibbet Mounting System (both at the rear) shown on a typical minivan or 4WD vehicles. Note the entire Antenna Main Assembly and partially Whip Section are **OBSTRUCTED** by vehicle metal panels. Communications will be affected.

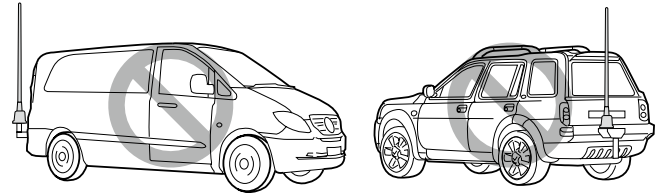

For best communications, position the antenna as high as possible. The Figure 1 shows the preferred option selection. The Figure 2 shows an antenna installation that uses the optional AH-5NV, for best communications on the 30–300km (18.6–186.5 miles) short ranges, and up to 1500 km (932 miles) medium ranges.

Figure 1

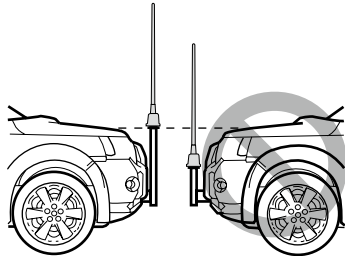
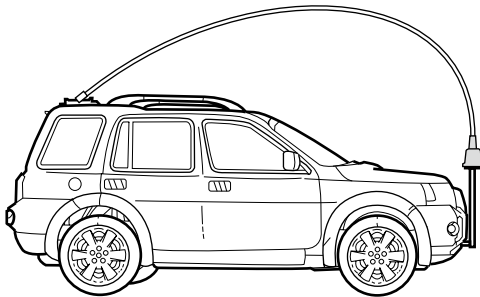

Figure 2



What is NVIS?

NVIS stands for Near Vertical Incidence Skywave. The NVIS radio-wave propagation provides usable signals between groundwave and skywave distances. (between 50 and 650 km, 30 and 400 miles) The radio waves from the antenna travel upwards into the ionosphere, and then are refracted back down in a circular area. The signals can be received up to 650 km (400 miles) from the transmitting station. Refraction fails if the frequency is too high. The signal strength is reduced if the frequency is too low, because of absorption.

◆ Precautions when the optional AH-5NV is installed on a vehicle

⚠ WARNING! The NVIS antenna element can swing a lot while driving. Therefore, we strongly recommend that you remove the NVIS antenna while driving. Otherwise the antenna element may swing excessively and interfere with your driving.

2 INSTALLATIONS

■ Installation outline

IMPORTANT!

The antenna is a critical element in any communication system. Correct installation is very important factor for achieving the utmost in antenna system performance and operation of your transceiver. We recommend that installation of the AH-740 be carried out by qualified technicians only.

- ① Attach a mounting base to a desired position on your vehicle.
 - Purchase the mounting base locally.
- ② Mount the AH-740 onto the mounting base.
 - See “Mounting” on the right side of this page for details.
- ③ Connect the control and coaxial cables between the transceiver and the AH-740.
 - See page 5 “Cable connections” for details.
- ④ Connect the ground strap to the vehicle’s chassis.
 - See page 5 “Cable connections” for details.
- ⑤ Attach the supplied antenna spring and whip onto the AH-740.

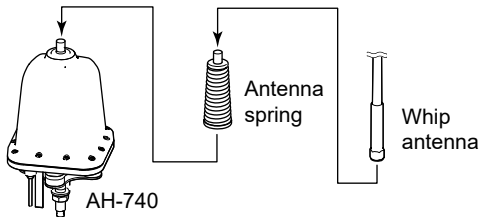

■ Mounting

⚠ WARNING! Mount the AH-740 securely with the supplied nuts and bolts. Otherwise, vibrations and shocks could loosen the antenna tuner, making it fall, causing personal injury.

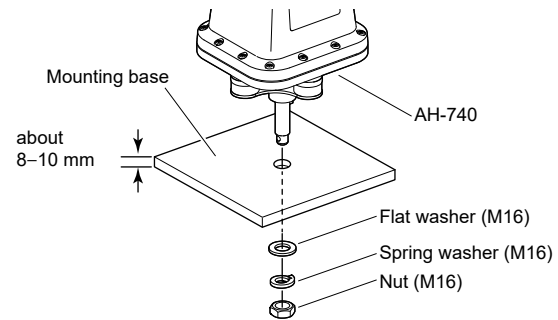

- For the greatest radiation effectiveness, position the antenna as high as possible.
- For human safety, mount the antenna at the front and opposite side of the driver's position, whenever possible.
 - Refer to the pictorial installations and scenarios shown on the pages 2 and 3.
- Make sure to allow enough clearance around the antenna so that any antenna flexing will not damage the vehicle—bear in mind that the Main Assembly can flex as much as 16 cm (6.3 inches), without damage.
- Make sure the antenna is as far from the vehicle's vertical and horizontal metal panels as possible.

- Mount the antenna on a mounting base with a 17 mm (0.67 inches) hole for the M16×2 mm (M0.63×0.08 inches) threaded mounting stud.
- Rotate the Main Assembly until the ground strap is directed towards the vehicle body, and then firmly tighten the nut.
- Use only the original hardware and proper tools.

■ Cable connections

- ① Connect the coaxial cable and the control cable to the AH-740.
 - Insert the control cable connector into the antenna body socket, then rotate the connector ring to lock it in place.
- ② Wrap the antenna connector with rubber vulcanizing tape, and then wrap electrical tape* over the rubber vulcanizing tape to secure waterproofing.

*The rubber vulcanizing tape and electrical tape are not supplied with the AH-740. Purchase them locally.
- ③ Secure both the coaxial and control cables to protect the inside connections.

Connect the coaxial cable and the control cable to the transceiver.

 - Connect the coaxial cable to an appropriate antenna connector.
 - Connect the control cable to the D-sub 9 pin type antenna tuner control connector, or the 4 pin type connector when the optional OPC-2321 is used.
 - See your transceiver's instruction manual for details.

- ④ Ground the transceiver, AH-740 and shield cable of the control cable to the ground terminal.

• Coaxial cable and control cable connections

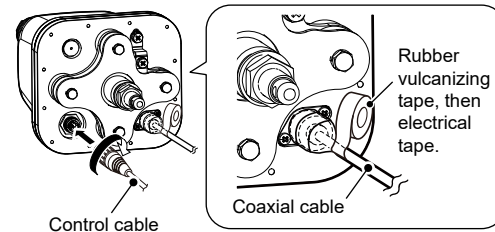

• Ground strap connection

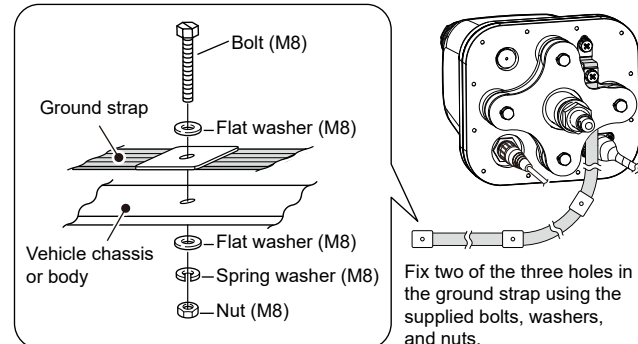

2 INSTALLATIONS

■ Optional AH-5NV

When using the AH-740 with the optional AH-5NV, install the AH-5NV as follows.

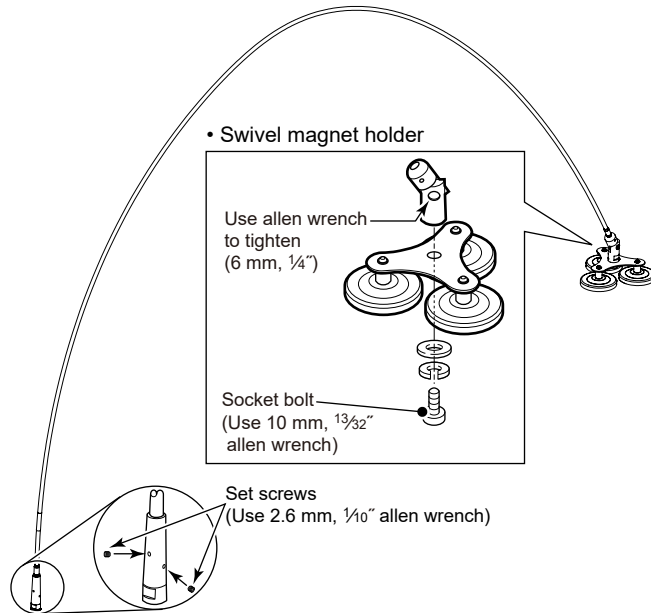

- ① Place the swivel magnet holder onto the vehicle, and attach the NVIS antenna element to the antenna spring of the AH-740.
 - Secure the antenna element by tighten the set screws.
- ② Insert the antenna element into the swivel magnet holder, as shown below.
- ③ Tighten the set screw.

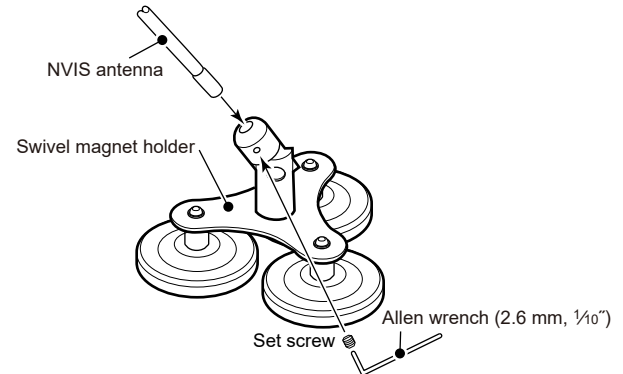

■ Specifications

- Frequency coverage: 2.2–30 MHz (with NVIS kit)
2.5–30 MHz (with supplied whip)
- Power supply requirement: 13.8 V DC (supplied from the HF transceiver)
- Current drain: Maximum 0.6 A
- Operating temperature range: –40°C to +70°C, –40°F to +158°F
- Antenna connector: SO-239
- Maximum Input power: 125 W (PEP)
- Automatic tuning time: Approximately 2 to 3 seconds (new frequency)
0.15 seconds (typical, retuning to a memorized frequency)
- Automatic tuning accuracy: SWR 1.5:1 or less (after tuning, except for multiples of $1/2\lambda$)
- Dimensions: 238 (H) × 145 (W) × 160 (D) mm, (projections not included)
9.4 (H) × 5.7 (W) × 6.3 (D) inches
- Weight (approximate): 3.5 kg, 7.7 lb (except whip and antenna spring)

All stated specifications are subject to change without notice or obligation.

◇ Control connector information

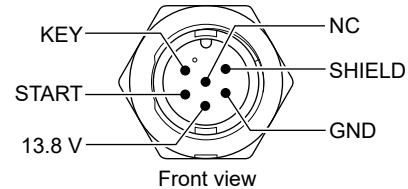

■ Options

• AH-5NV NVIS KIT

Approximately 4.5 m (14.8 ft) long antenna, covers 2.2 MHz through 30 MHz.

⚠ WARNING! At least two people are needed to unpack the optional AH-5NV NVIS KIT. Work in an open space as the element is tightly coiled and can spring open with a lot of force. This could cause a serious injury or other damage.

• OPC-2321 CONTROL CABLE

Approximately 6 m (19.7 ft) long control cable for Icom's amateur transceivers, that have a 4 pin type antenna tuner control connector.

How the World Communicates

A7088H-1EX-2
Printed in Japan
© 2013–2024 Icom Inc. Apr. 2024

Icom Inc.
1-1-32 Kamiminami, Hirano-ku, Osaka 547-0003, Japan