

WLAN TRANSCEIVER CONTROLLER IP1100CV

Thank you for choosing this Icom product.
READ ALL INSTRUCTIONS carefully and completely before using this product.

IMPORTANT

SAVE THESE INSTRUCTIONS— These instructions contain important precautions and the initial setup instructions for the IP1100CV WLAN TRANSCEIVER CONTROLLER (describes as “Controller” in this manual.) For the full operations, see the IP1100CV manuals available on the Icom website.
<https://www.icomjapan.com/support/>

EXPLICIT DEFINITIONS

WORD	DEFINITION
⚠ DANGER!	Personal death, serious injury or an explosion may occur.
⚠ WARNING!	Personal injury, fire hazard or electric shock may occur.
CAUTION	Equipment damage may occur.
NOTE	If disregarded, inconvenience only. No risk of personal injury, fire or electric shock.

Icom is not responsible for the destruction, damage to, or performance of any Icom or non-Icom equipment, if the malfunction is because of:

- Force majeure, including, but not limited to, fires, earthquakes, storms, floods, lightning, other natural disasters, disturbances, riots, war, or radioactive contamination.
- The use of Icom products with any equipment that is not manufactured or approved by Icom.

Icom and the Icom logo are registered trademarks of Icom Incorporated (Japan) in Japan, the United States, the United Kingdom, Germany, France, Spain, Russia, Australia, New Zealand, and/or other countries.
Microsoft and Windows are trademarks of the Microsoft group of companies.
Other trademarks and trade names are those of their respective owners.

Icom Inc.

1-1-32 Kamiminami, Hirano-ku, A7698W-1EX-2
Osaka 547-0003, Japan Printed in Japan
Jun. 2023 © 2022–2023 Icom Inc.

DISPOSAL



The crossed-out wheeled-bin symbol on your product, literature, or packaging reminds you that in the European Union, all electrical and electronic products, batteries, and accumulators (rechargeable batteries) must be taken to designated collection locations at the end of their working life. Do not dispose of these products as unsorted municipal waste. Dispose of them according to the laws in your area.

ABOUT CE

CE Versions of the IP1100CV which display the “CE” symbol on the serial number label comply with the essential requirements of the 2014/30/EU directive for Electromagnetic Compatibility and the 2001/95/EC directive for General Product Safety.

Below statement is for UKCA purpose only

United Kingdom Authorised Importer:
Icom (UK) Ltd.
Address: Blacksole House, Altira Park, Herne Bay, Kent,
CT6 6GZ, U.K.

To obtain the UKCA Declaration of Conformity, please contact Icom UK Limited by email at info@icomuk.co.uk or alternatively call + 44(0) 1227 741741.

PRECAUTIONS

◇ For the WLAN transceiver controller

⚠ DANGER! NEVER connect the ground terminal to a gas or electric pipe, since the connection could cause an explosion or electric shock.

⚠ WARNING! NEVER use a power adapter other than the specified one. This may result in an electrical shock, cause a fire, or damage the Controller and/or power adapter.

⚠ WARNING! NEVER install the Controller in an excessively humid place, or outdoors. This may result in an electric shock, cause a fire or damage the Controller.

⚠ WARNING! NEVER operate or touch the Controller with wet hands. This could cause an electric shock or damage the Controller.

⚠ WARNING! NEVER use the Controller during a lightning storm. It may result in an electric shock, cause a fire or damage the Controller. Always disconnect the power adapter before a storm.

⚠ WARNING! NEVER operate the equipment if you notice an abnormal odor, sound, or smoke. Immediately disconnect the power adapter. Contact your Icom dealer or distributor for advice.

⚠ WARNING! NEVER put the Controller in any unstable place (such as on a slanted surface or vibrating place). This may cause injury and/or damage to the Controller.

CAUTION: DO NOT install the Controller in areas with temperatures below 0°C (32°F) or above 40°C (104°F), or in areas subject to direct sunlight.

CAUTION: DO NOT expose the Controller to rain, snow or any liquids. They could damage the Controller.

CAUTION: DO NOT install the Controller in a place without air vents. Heat dissipation may be reduced, and this could damage the Controller.

CAUTION: DO NOT use the Controller in strong magnetic fields or in an area with high static electricity. This could damage the Controller.

CAUTION: DO NOT use harsh solvents such as Benzene or alcohol when cleaning. This could damage the equipment surfaces. If the surface becomes dusty or dirty, wipe it clean with a soft, dry cloth.

CAUTION: Confirm that all connectors and jacks are dry and clean before attachment. Exposing them to dust or water will result in serious damage to the Controller.

NEVER leave the Controller in an insecure place to avoid use by unauthorized persons.

DO NOT modify the Controller. The specifications may change and then the Controller may not comply with the requirements of required regulations. The Controller warranty does not cover any problems caused by unauthorized modification.

BE CAREFUL! The Controller may become hot after continuous use for long periods of time.

◇ For the optional power adapter

⚠ WARNING! NEVER use the power adapter with any device other than the Controller. This may result in an electric shock, cause a fire or damage the power adapter.

⚠ WARNING! CONNECT the adapter into an outlet between 100 V and 240 V AC. Otherwise, this may result in an electric shock, cause a fire or damage the Controller and/or the power adapter.

⚠ WARNING! NEVER use the power adapter to excessively humid place, outdoor, or near a humidifier. This may result in an electric shock, cause a fire or damage the power adapter.

⚠ WARNING! NEVER put something heavy on the power adapter cable. This may result in an electric shock, cause a fire or damage the power adapter.

⚠ WARNING! NEVER modify, bend by force, twist, pull or heat the power adapter's cable. This may result in an electric shock, cause a fire or damage the power adapter.

⚠ WARNING! NEVER touch the power adapter with wet hands. This may result in an electric shock or damage the power adapter.

◇ Other precautions

For information about operating the PC or external devices, refer to their instruction manuals for details.

The power adapter may at some time need to be replaced, depending on its life expectancy. The life of a power adapter differs according to the environment or condition in which the adapter is used.

We recommend replacement when it has been used for approximately 5 years (When used under the ambient temperature of 25°C (77°F)). Contact your local dealer for details.

FCC INFORMATION

This equipment has been tested and found to comply with the limits for a Class B digital device, pursuant to part 15 of the FCC Rules. These limits are designed to provide reasonable protection against harmful interference in a residential installation. This equipment generates, uses, and can radiate radio frequency energy and, if not installed and used in accordance with the instructions, may cause harmful interference to radio communications. However, there is no guarantee that interference will not occur in a particular installation. If this equipment does cause harmful interference to radio or television reception, which can be determined by turning the equipment off and on, the user is encouraged to try to correct the interference by one or more of the following measures:

- Reorient or relocate the receiving antenna.
- Increase the separation between the equipment and receiver.
- Connect the equipment into an outlet on a circuit different from that to which the receiver is connected.
- Consult the dealer or an experienced radio/TV technician for help.

CAUTION: Changes or modifications to this device, not expressly approved by Icom Inc., could void your authority to operate this device under FCC regulations.

◇ FCC SDoC

This device complies with part 15 of the FCC Rules. Operation is subject to the following two conditions: (1) This device may not cause harmful interference, and (2) this device must accept any interference received, including interference that may cause undesired operation.

Responsible Party

Company Name: Icom America Inc.
Address: 12421 Willows Road NE
Kirkland, WA 98034

U.S. Contact Information

800-USA-ICOM (800-872-4266)
Monday – Friday 7 AM to 5 PM PST

This device must not be co-located or operated in conjunction with any other antenna or transmitter.

PRECAUTIONS ON USING THE WIRELESS LAN

- We recommend that users with pacemakers take precautions to be sure that this device does not cause them a problem because of electromagnetic interferences.
- DO NOT** use this device near microwave ovens. A microwave oven may cause electromagnetic interference to the communications through this device.
- DO NOT** modify the device. The device warranty does not cover any problems caused by unauthorized modification.

INFORMATION FCC

Cet appareil est conforme à la partie 15 de la réglementation FCC. Son fonctionnement est soumis à la condition que cet appareil ne provoque pas d'interférences nocives. Cet équipement a été testé et reconnu conforme aux limites fixées pour un appareil numérique de classe B, conformément à la partie 15 de la réglementation FCC. Ces limites ont été fixées afin d'assurer une protection raisonnable contre les interférences nocives dans une installation résidentielle. Cet équipement génère, utilise et peut émettre un rayonnement de fréquence radio. S'il n'a pas été installé conformément aux instructions, il peut par ailleurs créer des interférences perturbant les communications radio. Toutefois, il n'y a aucune garantie que les interférences ne se produiront pas dans une installation particulière. Si cet équipement crée des interférences perturbant la réception de la radio ou de la télévision, comme cela peut être déterminé en éteignant et en allumant l'équipement, l'utilisateur est invité à essayer de corriger l'interférence en prenant une ou plusieurs des mesures ci-après :

- Réorienter ou changer de place l'antenne de réception.
- Éloigner l'équipement et le récepteur.
- Connecter l'équipement sur une prise sur un autre circuit que celui sur lequel le récepteur est connecté.
- Faire appel au revendeur ou à un technicien radio/TV expérimenté.

MISE EN GARDE : Tout changement ou modification, non expressément approuvé par Icom Inc., peut annuler l'autorisation de l'utilisateur à utiliser cet appareil conformément à la réglementation FCC.

Cet appareil est conforme à la partie 15 de la réglementation FCC. Son utilisation est soumise au respect de deux conditions : (1) Cet appareil ne doit pas causer d'interférences nuisibles et (2) cet appareil doit accepter toute interférence reçue, y compris les interférences pouvant entraîner un fonctionnement non désiré.

Cet appareil ne doit pas être situé ou utilisé en conjonction avec une autre antenne ou un autre émetteur.

PRÉCAUTIONS POUR L'UTILISATION DU RÉSEAU LOCAL SANS FIL

- Nous recommandons aux utilisateurs portant un stimulateur cardiaque de s'assurer que cet appareil ne cause pas de problème d'interférences électromagnétiques.
- NE PAS** utiliser cet appareil à proximité d'un four à micro-ondes. Un four à micro-ondes peut provoquer des interférences électromagnétiques pendant les communications à l'aide de cet appareil.
- NE PAS** modifier l'appareil. L'appareil ne couvre pas les problèmes résultant d'une modification non autorisée.

SUPPLIED ACCESSORIES

Item	Quantity
• Clamp	1
• Set screw (for the clamp)	1
• Magnetic leg	4
• Screw (for the magnetic leg)	4
• Cushion sheet	1

① Some accessories are not supplied, or the shape is different, depending on the Controller version.

OTHER REQUIREMENTS

- BC-207S or BC-236 AC ADAPTER (Purchase separately)
- LAN cable (User supplied)
- Grounding cable (User supplied)
- PC for the setup operation
- Wireless access point (Purchase separately)

① You can install the IP1100CV into the 19-inch rack using an optional MBF-6 MOUNTING BRACKET. See the manual supplied with the bracket for details on the installation.

CAUTION for the magnetic legs

The supplied magnetic legs contain strong magnets.

- Be careful not to pinch your fingers with the magnet.
- Do not bring the magnet close to or hit the implant site, such as a cardiac pacemaker. It could cause an unexpected operation of electronic medical devices and could be dangerous to life.
- Keep the magnet away from such as watches, IC cards, compasses, and precision instruments.

OPTIONS

- **BC-207S AC ADAPTER**
 - ① BC-236 AC ADAPTER is also usable instead of the BC-207S.
- **MBF-6 MOUNTING BRACKET** for a 19 inch rack

DIMENSIONS

(Approximate, projections not included)

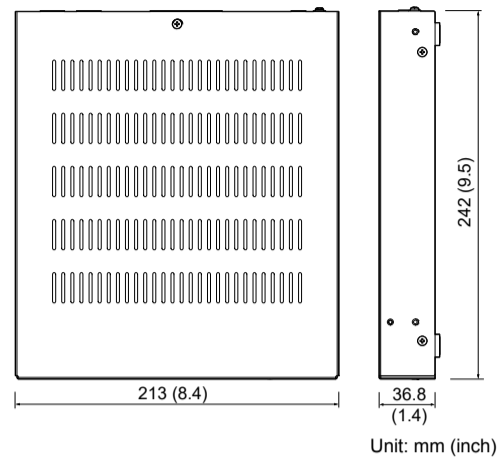

PANEL DESCRIPTION

Front panel

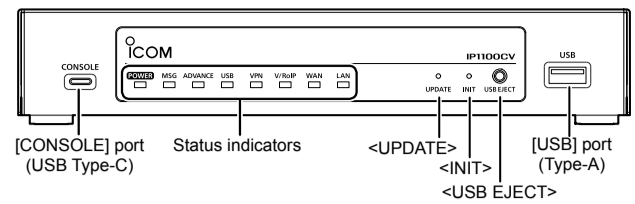

Rear panel

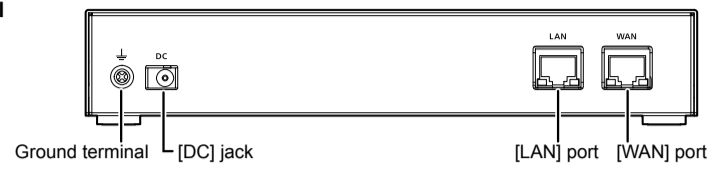

Status indicators

See the INSTALLATION GUIDE for details on the indications.

INDICATOR	LIT	BLINKS	NOT LIT
POWER	Green: Power ON Orange: Booting up Red: Boot loader prompt stopped	Green: Booting up/Loading a firmware Red: (See the INSTALLATION GUIDE)	Other condition
MSG	Green: (Online Update) A firmware update is ready	Green: (Online Update) Downloading a firmware update	Other condition
ADVANCE	– (Reserved for a future function)	–	Any condition
USB	Green: A USB flash drive is connected Red: Failed updating the firmware or failed reading from a USB flash drive	Green: Accessing the USB flash drive	A USB flash drive is unmounted or not connected
VPN	Green: At least one IPsec tunnel has been established	–	Not connected VPN not used Invalid setting
V/RoIP	Green: At least one WLAN transceiver has been successfully registered	–	Other condition
WAN	Green: Connected to the WAN (PPPoE) PPP has been established (DHCP client) IP address obtained	Red: (PPPoE) Authentication failure (DHCP client) Failed to obtain an IP address	Other condition
LAN	Green: Connected to a LAN	–	Other condition

INITIALIZING THE CONTROLLER

If you cannot access the Controller Setting screen, such as when you lose your IP address or password, you will not be able to access the Controller Setting screen unless you reset the Controller to factory defaults.

1. Remove all the devices from the Controller except for the power adapter.
2. Hold down the <INIT> button for 3 seconds.
 - ① The Controller restarts and loads its factory defaults.

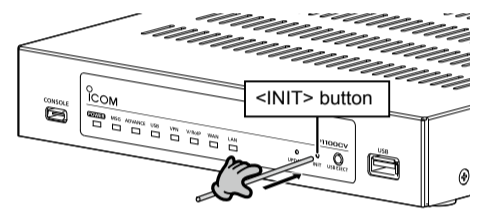

① See the INSTALLATION GUIDE (PDF manual) for resetting on the Setting screen.

CONNECTIONS

Disconnect the PC from your network before connecting the Controller.

1. Attach the 4 supplied cushions onto the bottom panel as shown to the right.
 - ① To attach the supplied magnetic legs, refer to the INSTALLATION GUIDE for details.
2. Connect the power adapter (purchase separately,) grounding cable, and the LAN cable to the Controller.
3. Connect the power adapter to an AC outlet.
 - ① The Controller turns ON and then the Power indicator on the front panel lights green.
4. Turn ON your PC.
 - ① If the LAN indicator on the front panel does not light, check the LAN cable connection.

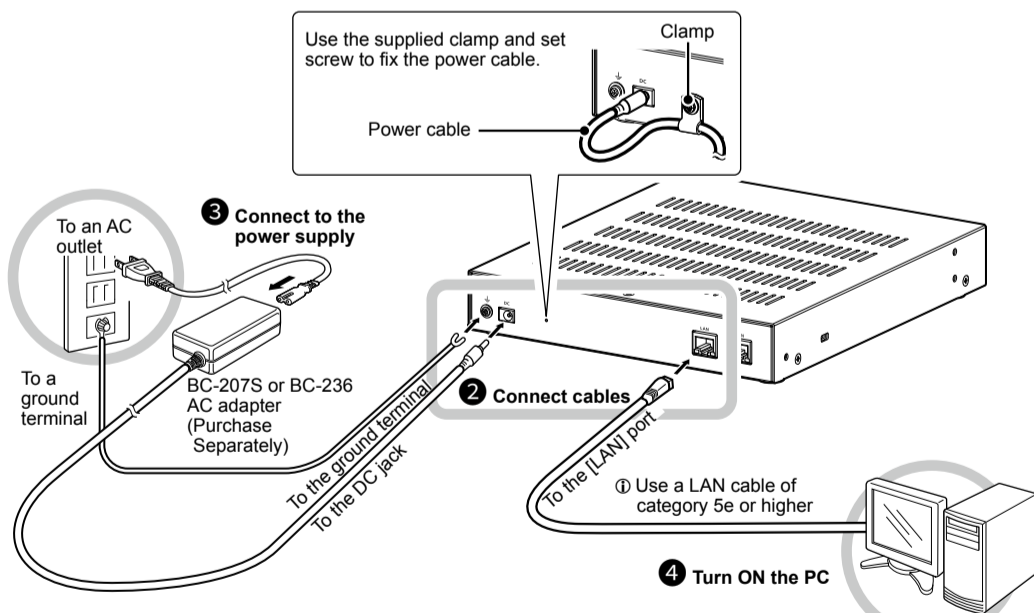
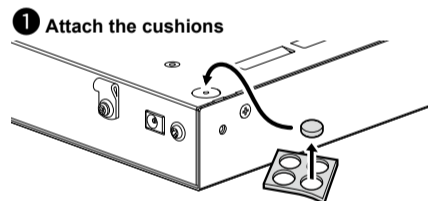

PC for setting up the Controller
(IP address example : 192.168.0.100)

⚠ WARNING!

- To prevent electrical shock, television interference (TVI), broadcast interference (BCI) and other problems, ground the Controller through the ground terminal.
- Make the distance between the ground terminal and ground as short as possible.
- **NEVER** connect the ground terminal to a gas or electric pipe. This may result in an electrical shock or cause a fire.

⚠ WARNING! NEVER use other than the specified power adapter. This may result in an electrical shock, cause a fire or damage the Controller.

IP address for the PC
The IP1100CV's IP address is set to "192.168.0.1" and the DHCP server to "Disable" as the default. Set a fixed IP address on your PC (Example: 192.168.0.100) to access the IP1100CV.

THE INITIAL LOGIN

Accessing the Setting screen

You can access the Setting screen of the Controller using a web browser on the PC.

About web browsers:

- Microsoft Edge (Chromium based) is a recommended web browser.
- Enable JavaScript® and set to accept cookies on your web browser to correctly display the Setting screen.
- The Setting screen may not be correctly displayed, depending on the browser.

1. Enter the IP address of the IP1100CV "http://192.168.0.1/" (as the default) into the address bar of your web browser, and then press the [Enter] key.

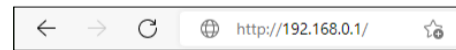

- The Initial Login screen is displayed.

2. Enter a new password into both "New Password" and "New Password (Confirm)," and then click <Apply>.
 - ① The password should be up to 31 of characters, numbers, and letters (case sensitive.)
 - ② You can check the entered characters by clicking the eye icon to the right.

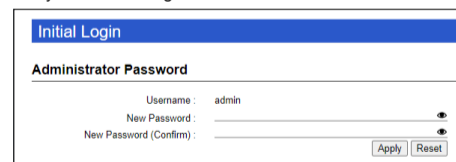

- The Login Authentication screen is displayed.

3. Enter the user name "admin" (fixed username) and the password set in Step 2, and then click <Sign in>.

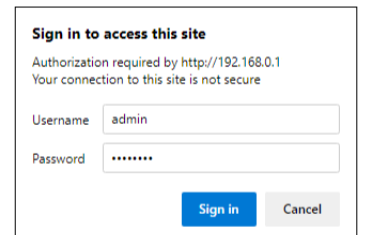

- The IP1100CV Setting screen is displayed.

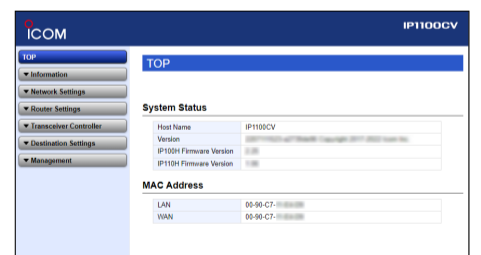

① For details on the Setting screen operation, see the PDF manuals supplied on the Icom web site.

To prevent unauthorized access:

- Choose a password that is not easy to guess.
- Use numbers, characters, and letters (both lower and upper case).
- See the OPERATING GUIDE for details on setting the password.

THE SETTING SCREEN

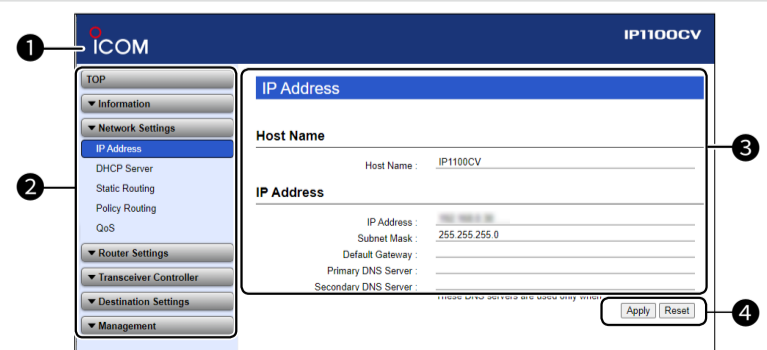

1 Link to the Icom web site

If your PC is connected to the Internet, click the Icom logo to open the Icom web site.

2 Menu list

Displays the list on a menu line. When you click each menu, a list of the submenus drops down so you can click to display the Setting screen to the right.

3 Setting screen

Displays the settings and values when you click a submenu item to the left.

4 Buttons

Applies or resets the setting values.
① The displayed buttons differ, depending on the screen.